



# HEICO-TEC® TENSIONING SYSTEMS



## HEICO-TEC® TENSIONING SYSTEMS

- Pretension large bolted joints easily, quickly and precisely
- High preload force due to torsion-free mounting
- Controlled friction conditions ensure maximum tightening and repeatable accuracy
- No recovery losses; bolt strength can be fully utilized
- Tension nuts and reaction nuts are compatible with conventional strength classes according to ISO 898-2
- Reusable several times
- Available as standard from M20 - M160 in property class 8 and M20 - M100 in property class 10
- Other property classes, customer-specific sizes, pitches, thread forms or materials are available on request

	<b>HEICO-TEC®</b> PRODUCT OVERVIEW	> Page 04
	<b>HEICO-TEC®</b> TENSION NUT	> Page 06
	<b>HEICO-TEC®</b> COMPACT SERIES	> Page 14
	<b>HEICO-TEC®</b> REACTION NUT	> Page 20
	<b>HEICO-TEC®</b> TENSION BOLT	> Page 28
	<b>HEICO-TEC®</b> MULTI-TOOL	> Page 28
	<b>HEICO-TEC®</b> PROTECTION CAP	> Page 29
	<b>HEICO-TEC®</b> ACCESSORIES	> Page 34
	<b>HEICO</b> SERVICE AND QUALITY	> Page 38



# HEICO-TEC® PRODUCT OVERVIEW

# HEICO-TEC® PRODUCT OVERVIEW

HEICO-TEC® Product- description	TENSION NUTS					
	HTM/8	HTM/10	HTM/BH	HTM/CH	HTM/DH	HTM/LT
<b>Description</b>	ISO 898-2 Class 8	ISO 898-2 Class 10	ASTM A563 Grade B	ASTM A563 Grade C	ASTM A563 Grade D	Large-Ø Light Series
<b>Application</b>	Replacement for hexagon nut class 8 Pressure device according to 2014/68/EU (DGRL) and TÜV AD 2000	Replacement for hexagon nut class 10	Replacement for hexagon nut	Replacement for hexagon nut	Replacement for hexagon nut	Large thread diameters Easy to mount
<b>Operation Temperature</b>	-20°C ÷ 300°C	-20°C ÷ 300°C -40°C and -60°C Upon request	-20°C ÷ 300°C	-20°C ÷ 300°C	-20°C ÷ 300°C -40°C and -60°C Upon request	-20°C ÷ 300°C
<b>Dimensions</b>	M20 - M160 Height (0,8 - 1) x D Outer-Ø (1,8 - 2) x D	M20 - M100 Height (0,8 - 1) x D Outer-Ø (1,8 - 2) x D	1" - 6" Height > 0,8 x D Outer-Ø ca. 1,5 x D	1" - 5" Height > 0,8 x D Outer-Ø (1,6 - 2) x D	1" - 4" Height > 0,8 x D Outer-Ø (1,8 - 2) x D	M90 - M250 Height < 0,8 x D Outer-Ø < 1,6 x D
<b>Bolt Tension</b>	Max.: 640 MPa  Recommended: 50 - 85% of max.	Max.: 900 MPa  Recommended: 50 - 85% of max.	Max.: ≤ 470 MPa (≤ 68 ksi) Recommended: 50 - 85% of max.	Max.: ≤ 600 MPa (≤ 87 ksi) Recommended: 50 - 85% of max.	Max.: ≤ 800 MPa (≤ 115 ksi) Recommended: 50 - 85% of max.	Max.: ≤ 110 MPa Recommended: 50 - 75% of max.
<b>Suitable Reaction Nut HTR</b>	HTR/8	HTR/10	Upon request	HTR/CH	HTR/DH	Upon request

COMPACT SERIES		REACTION NUT		TENSION BOLT	
HTM/FL	HTM/FS	HTR/8	HTR/10	HTS/8.8	HTZ/8.8
Flat Light Series	Flat Heavy Series	ISO 898-2 Class 8	ISO 898-2 Class 10	ISO 898-1 Class 8.8	ISO 898-1 Class 8.8
Confined spaces  Optionally with captive pressure bolts for rotating parts, e.g. shaft nuts Counter threaded connections, e.g. hydraulic cylinders	Confined spaces  Optionally with captive pressure bolts for rotating parts, e.g. shaft nuts Counter threaded connections, e.g. hydraulic cylinders	Replacement for hexagon nut class 8  Use with HTM/8	Replacement for hexagon nut class 10  Use with HTM/10	Replacement for hexagon bolt ISO 4014  Head takes up less space than a nut	Replacement for socket cap bolt acc. to ISO4762  Confined spaces Head takes up less space than a nut
-20°C ÷ 300°C	-20°C ÷ 300°C	-20°C ÷ 300°C	-20°C ÷ 300°C -40°C and -60°C Upon request	-20°C ÷ 300°C	-20°C ÷ 300°C
M20 - M160 1" - 6"	M20 - M160 1" - 6"	M20 - M160 Height (0,8 - 1) x D Outer-Ø (1,8 - 2) x D	M20 - M100 Height (0,8 - 1) x D Outer-Ø (1,8 - 2) x D	M20 - M160	M20 - M160 Head fits into countersink according DIN 74
Max.: ≤ 130 MPa  Recommended: 50 - 75% of max.	Max.: ≤ 300 MPa  Recommended: 50 - 75% of max.	Max.: 640 MPa  Recommended: 50 - 85% of max.	Max.: 900 MPa  Recommended: 50 - 85% of max.	Max.: 640 MPa  Recommended: 50 - 75% of max.	Max.: 640 MPa  Recommended: 50 - 75% of max.
Upon request	Upon request			HTR/8	HTR/8

LOT: 23648001-201726109  
 LUBRICANT: WEICON AS

# HEICO-TEC® TENSION NUT

## SIMPLE · FAST · RELIABLE

For a secure joint with a HEICO-TEC® Tension Nut, no electric, hydraulic, or pneumatic tools are needed. All you need is a torque wrench.

The HEICO-TEC® Tension Nut is unique in the fact that the pretension force of the large main thread is distributed to many smaller pressure bolts. Because the pressure bolts are smaller, a conventional torque wrench can be used to achieve the correct pretension force.

This eliminates the need for complex, bulky, or heavy tools and makes securing large bolted joints more convenient and easy.



## DESIGN AND FUNCTION

1. The nut body ① is screwed onto the main thread just like a conventional nut – but is not tightened.
2. Several pressure bolts ②a with associated pressure pins ②b are arranged around the main thread inside the nut body. When the pressure bolts are tightened, they push the pressure pins against the part to be tensioned and at the same time the bolt elongates. The pretension force created in this way is purely axial and therefore free from harmful torsion or bending.
3. The hardened incorporated thrust washer ③ protects the tensioned parts from high pressure loads caused by the pressure pins.

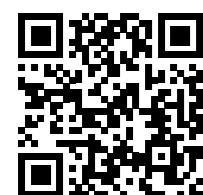
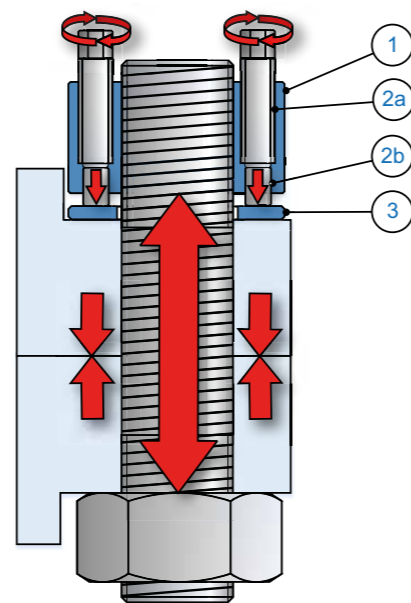

Scan the QR code for the video of the functional principle of the tension nut.

# ADVANTAGES OF HEICO-TEC® TENSION NUT



### SIMPLE

A hand-held torque wrench is all you need for tightening and loosening. No special tools are required. This makes maintenance far easier.



### FAST

Manual pretensioning saves on the transport and set-up times that would be required by special tools. HEICO-TEC® Tension Nuts are often tightened in the same time it takes to set up electric, hydraulic or pneumatic tools.



### RELIABLE

The pressure pins act like springs and increase the flexibility of the bolted joint. This compensates for settlement of the joint, thus preserving preload.



### SAFE

With the inherent mechanical elasticity of the HEICO-TEC® design, the bolted joint performs as if it has a greater clamping length, making it highly resistant to loosening forces.



### DURABLE

The greater elasticity reduces the bolted joint's dynamic stress, thus increasing its service life.



### PRECISE

Controlled friction characteristics ensure the highest tightening and repeat accuracy – guaranteed and confirmed by DNV GL.



### REUSABLE

As the HEICO-TEC® assembly is not damaged during tightening and loosening, the HEICO-TEC® Tension Nuts are reusable.



### COMPATIBLE

HEICO-TEC® Tension Nuts comply with all ISO 898-2 requirements. You can directly replace any conventional nut from the same strength class.



### ECONOMICAL

Our efficient and high volume manufacturing process means that we can transfer the cost benefits directly to our customers.



## HEICO-TEC® TENSION NUT

## HEICO-TEC® TENSION NUT

Compared with conventional methods, HEICO-TEC® Tension Nuts offer considerable advantages for tensioning large bolted joints quickly, simply and reliably.

### PHYSICS OF BOLT TENSIONING PROCESS

Due to the inclined plane of the bolt threads, the turning movement of bolt tightening results in axial elongation and pre-load of the bolt.

#### Problems:

- Threads are deformed even when proper lubrication is applied.
- The deformation of the threads reduces the pre-load, durability and reusability of the bolt.
- The torsion stress from thread friction and deformation reduces the axial load-bearing capacity of the bolt.

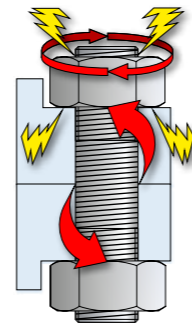

#### ADVANTAGES OF HEICO-TEC®

No torsion stress. As the stress on the bolt is purely axial, the capacity of the bolt can be fully utilized.

### THE HYDRAULIC TENSIONING PROCESS

When tightening a bolt with a hydraulic cylinder, the bolt is elongated and the nut is then tightened free of load. When the hydraulic pressure is released, the bolt contracts, resulting in the proper tension on the bolt.

#### Problem:

As the nut was not pre-tensioned while the bolt was elongated, a percentage of the elongation of the bolt is lost in joint settlement. Only two thirds of the bolt strength can be utilized.

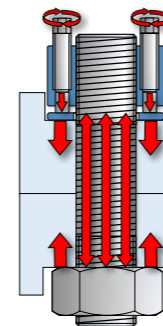

#### ADVANTAGES OF HEICO-TEC®

Losses from settlement of the joint do not occur and full capacity of the joint is achieved.

### TENSION NUTS WITH PRESSURE BOLTS PROCESS

In the case of tension nuts with only pressure bolts, the pressure bolts are arranged closer to the bolt thread and have a smaller hexagon head.

#### Problems:

- With less space to maneuver, this tensioning system results in higher costs due to the need for a special thin-walled socket and wrench.
- Typically, this tension system is not as strong as standard hex nuts. In this case, standard tension nuts with pressure bolts cannot replace commercial hex nuts.

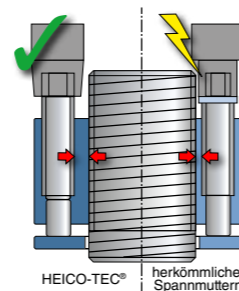

#### ADVANTAGES OF HEICO-TEC®

Nuts can be installed with standard industrial-quality wrenches.

### STANDARD SERIES 8 AND 10

HEICO-TEC® Tension Nuts of grade 8 and 10 meet all the requirements of ISO 898-2 and can be combined with the appropriate bolts of strength classes 8.8 or 10.9. In particular, they all have passed load tests at a state material testing institute (Materialprüfanstalt (MPA)) under the supervision of independent observers (DNV GL and TÜV Süd).

Therefore, HEICO-TEC® series 8 and series 10 Tension Nuts can substitute hexagon nuts of the same strength class without impairing the structural safety of the bolted connection. All calculations and approvals to which the machine or system is subjected remain valid.

### PRESSURE VESSEL APPLICATIONS

Pressure vessels traditionally use conventional hexagon nuts with corresponding proof strengths according to ISO 898-2. HEICO-TEC® Tension Nuts of strength class 8 (according to ISO 898-2) have been approved by the TÜV for general suitability and proof of equivalence.

Thus, conventional hex nuts of strength class 8 can be replaced through HEICO-TEC® Tension Nuts of the same strength class.



### ASSEMBLY INSTRUCTIONS

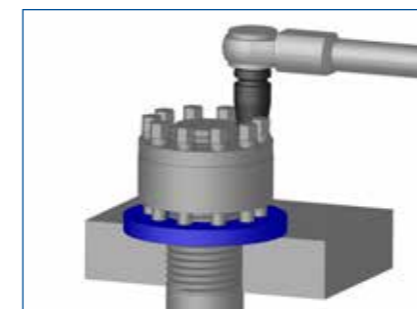

#### Soft Materials

The use of a larger and thicker incorporated load spreading washer will be required for use with soft materials (e.g. aluminum) or sensitive surfaces. HEICO can provide these incorporated washers on request.

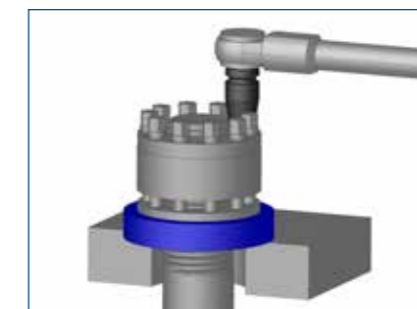

#### Large Holes or Slots

The incorporated washer must be fully supported under the pressure pins, otherwise the washer could bend or break. In the case of large holes or slots, an additional supporting incorporated washer must be used.

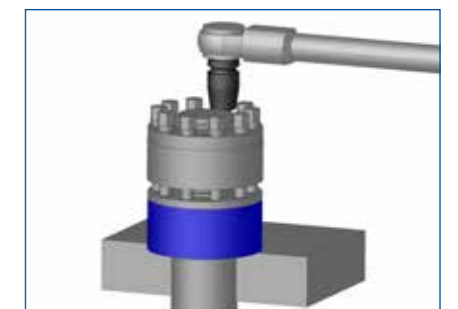

#### Protruding Bolt Ends

If the bolt ends protrude too far through the joint an additional incorporated washer can be provided to position the HEICO-TEC® Tension Nut properly.

# HEICO-TEC® TENSION NUT (METRIC)

## PRODUCT OVERVIEW

### STRENGTH CLASS 8



Scan to download the 3D-Data

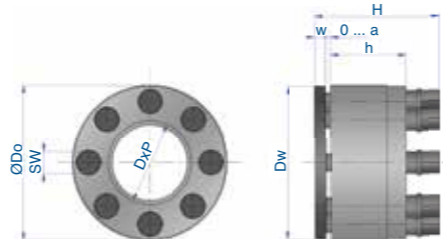

Type	Nut body		Pressure bolts	Washer	Tension nut		Torque	Preload				
	Thread DxP	Outer-Ø D <sub>o</sub> [mm]			Height h [mm]	Quantity n		Width across flats SW [mm]	Outer-Ø D <sub>w</sub> [mm]	Thickness w [mm]	Total height H [mm]	Tensioning stroke a [mm]
HTM-M20x2,5/8	M20x2,5	40	20	7	6	39	4	37	4,5	12	125	160
HTM-M22x2,5/8	M22x2,5	42	20	8	6	41	4	37	4,5	14	165	190
HTM-M24x3/8	M24x3	44	20	10	6	43	4	37	4,5	13	195	225
HTM-M27x3/8	M27x3	50	24	8	7	49	4	42	5,0	24	245	285
HTM-M30x3,5/8	M30x3,5	56	28	9	8	55	5	50	5,5	30	300	360
HTM-M33x3,5/8	M33x3,5	59	28	10	8	58	5	50	5,5	33	365	445
HTM-M36x4/8	M36x4	69	35	7	10	68	5	60	7,5	70	440	525
HTM-M39x4/8	M39x4	72	35	8	10	71	5	60	7,5	73	525	625
HTM-M42x4,5/8	M42x4,5	75	35	9	10	74	5	60	7,5	74	600	720
HTM-M45x4,5/8	M45x4,5	84	42	8	12	83	6	73	9,5	115	685	840
HTM-M48x5/8	M48x5	87	42	9	12	86	6	73	9,5	120	805	945
HTM-M52x5/8	M52x5	91	42	10	12	90	6	73	9,5	125	930	1125
HTM-M56x5,5/8	M56x5,5	102	52	8	14	101	8	87	10,5	205	1095	1300
HTM-M60x5,5/8	M60x5,5	106	52	9	14	105	8	87	10,5	210	1260	1500
HTM-M64x6/8	M64x6	110	52	10	14	109	8	87	10,5	215	1435	1665
HTM-M68x6/8	M68x6	120	64	9	16	119	8	104	12,5	315	1645	1930
HTM-M72x6/8	M72x6	124	64	10	16	123	8	104	12,5	320	1855	2145
HTM-M76x6/8	M76x6	128	64	12	16	127	8	104	12,5	300	2090	2490
HTM-M80x6/8	M80x6	132	76	13	16	131	8	116	12,5	310	2340	2780
HTM-M85x6/8	M85x6	137	76	15	16	136	8	116	12,5	305	2655	3170
HTM-M90x6/8	M90x6	149	88	13	18	148	10	130	12,5	445	3005	3580
HTM-M95x6/8	M95x6	154	88	15	18	153	10	130	12,5	430	3350	4020
HTM-M100x6/8	M100x6	159	88	16	18	158	10	130	12,5	450	3740	4480
HTM-M105x6/8	M105x6	170	100	14	20	169	10	147	14,5	635	4165	4965
HTM-M110x6/8	M110x6	175	100	15	20	174	10	147	14,5	650	4570	5400
HTM-M115x6/8	M115x6	186	112	17	20	185	10	159	14,5	630	5020	6015
HTM-M120x6/8	M120x6	195	112	18	20	194	10	159	14,5	655	5525	6490
HTM-M125x6/8	M125x6	203	124	14	21	202	12	176	18,5	910	6000	7125
HTM-M130x6/8	M130x6	208	124	16	21	207	12	176	18,5	860	6510	7775
HTM-M140x6/8	M140x6	215	124	18	21	214	12	176	18,5	895	7600	9075
HTM-M150x6/8	M150x6	236	139	20	21	235	12	191	18,5	930	8775	10190
HTM-M160x6/8	M160x6	272	139	23	21	271	12	191	18,5	925	10030	11735

\* Tightening torque per pressure bolt  
 \*\* approx. 2/3 of the breaking load of a bolt of strength class 8.8 (tested according to ISO 898-2 up to M120)  
 \*\*\* F<sub>Vmax</sub> is the maximum bolt load (FS) that the locknut can withstand (i.e. preload + additional bolt load). This force value must not be exceeded.  
 In the event that larger forces have to be generated or endured, the use of HEICO-TEC® strength class 10 is recommended.

# HEICO-TEC® TENSION NUT (METRIC)

## PRODUCT OVERVIEW

### STRENGTH CLASS 10



Scan to download the 3D-Data

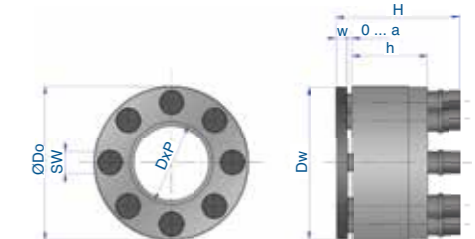

Type	Nut body				Pressure bolts	Washer	Tension nut		Torque	Preload					
	Thread D	Pitch P	Outer-Ø D <sub>o</sub> [mm]	Height h [mm]			Quantity n	Width across flats SW [mm]		Outer-Ø D <sub>w</sub> [mm]	Thickness w [mm]	Total height H [mm]	Tensioning stroke a [mm]	Nominal* M <sub>A</sub> [Nm]	Nominal** F <sub>Vnom</sub> [kN]
HTM-M20x.../10	M20	2,5	2	1,5	40	20	10	6	39	4	37	4,5	12	180	220
HTM-M22x.../10	M22	2,5	2	1,5	42	20	12	6	41	4	37	4,5	13	235	265
HTM-M24x.../10	M24	3,0	2	1,5	46	24	9	7	45	4	42	5,0	22	260	320
HTM-M27x.../10	M27	3,0	2	1,5	50	24	12	7	49	4	42	5,0	22	350	410
HTM-M30x.../10	M30	3,5	2	1,5	56	28	12	8	55	5	50	5,5	31	425	505
HTM-M33x.../10	M33	3,5	2	1,5	66	33	8	10	65	5	56	5,5	70	515	625
HTM-M36x.../10	M36	4,0	3	1,5	69	35	10	10	68	5	60	7,5	67	620	740
HTM-M39x.../10	M39	4,0	3	1,5	72	35	12	10	71	5	60	7,5	66	725	880
HTM-M42x.../10	M42	4,5	3	1,5	81	40	10	12	80	6	69	7,5	110	845	1010
HTM-M45x.../10	M45	4,5	3	1,5	84	42	11	12	83	6	73	9,5	115	975	1180
HTM-M48x.../10	M48	5,0	3	1,5	88	42	12	12	87	6	73	9,5	120	1110	1330
HTM-M52x.../10	M52	5,0	3	2,0	98	50	11	14	97	8	84	9,5	180	1320	1585
HTM-M56x.../10	M56	5,5	4	2,0	102	52	12	14	101	8	87	10,5	190	1520	1830
HTM-M60x.../10	M60	5,5	4	2,0	110	52	13	14	109	8	87	10,5	205	1780	2130
HTM-M64x.../10	M64	6,0	4	2,0	116	60	12	16	115	8	100	12,5	290	2020	2420
HTM-M68x.../10	M68	6,0	4	2,0	120	64	13	16	119	8	104	12,5	305	2300	2750
HTM-M72x.../10	M72	6,0	4	2,0	134	64	12	18	133	10	106	12,5	415	2585	3120
HTM-M76x.../10	M76	6,0	4	2,0	138	72	13	18	137	10	115	13,5	435	2935	3510
HTM-M80x.../10	M80	6,0	4	2,0	147	72	14	18	146	10	115	13,5	450	3270	3910
HTM-M85x.../10	M85	6,0	4	2,0	150	84	13	20	149	10	131	14,0	505	3700	4460
HTM-M90x.../10	M90	6,0	4	2,0	160	84	14	20	159	10	131	14,0	530	4185	5040
HTM-M95x.../10	M95	6,0	4	2,0	173	94	11	21	172	12	146	18,5	910	4700	5560
HTM-M100x.../10	M100	6,0	4	2,0	182	94	12	21	181	12	146	18,5	930	5245	6110

The exact article designation is generated by replacing the „...“ with the desired gradient.

\* Tightening torque per pressure bolt  
 \*\* approx. 2/3 of the breaking load of a bolt of strength class 8.8 (tested according to ISO 898-2 up to M120)  
 \*\*\* F<sub>Vmax</sub> is the maximum bolt load (FS) that the locknut can withstand (i.e. preload + additional bolt load). This force value must not be exceeded.  
 In case that larger forces have to be generated or endured, the use of HEICO-TEC® strength class 10 is recommended. Contact HEICO to determine viable options.

All series of HEICO-TEC® Tension Nuts are marked with the strength class according to ISO 898-2. Other strength classes, sizes, pitches or thread forms are available on request.

All HEICO TEC® Tension Nuts can optionally be ordered with a zinc flake coating for better protection against corrosion. Other coatings or stainless steel finishes are available upon request.

More information about the HEICO-TEC® Tension Nuts can be found at [www.heico-tec.com](http://www.heico-tec.com)



# HEICO-TEC® TENSION NUT (INCH)

# HEICO-TEC® TENSION NUT (INCH)

## PRODUCT OVERVIEW

### GRADE BH

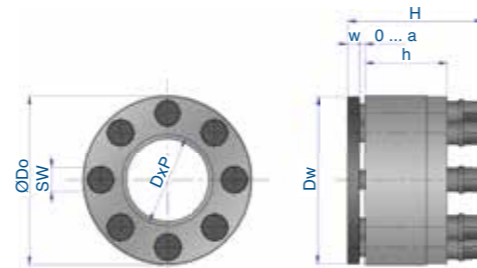

Type	Nut body			Pressure bolts		Washer		Tension nut		Torque	Preload		
	Thread D-tpi	Outer-Ø D <sub>o</sub> [in]	Height h [in]	Quantity n	Width across flats SW [mm]	Outer-Ø D <sub>w</sub> [in]	Thickness w [in]	Total height H [in]	Tensioning stroke a [in]		Nominal* M <sub>A</sub> [lbf]	Nominal** F <sub>Vnom</sub> [lbs]	Maximum*** F <sub>Vmax</sub> [lbs]
HTM-D-TPI/BH													
HTM-4 3/4"-4UN/BH	4 3/4"-4UN	7,32	4,41	15	20	7,28	0,39	6,26	0,57	420	900'000	1'200'000	
HTM-5"-4UN/BH	5"-4UN	7,68	4,41	17	20	7,52	0,39	6,26	0,57	413	1'002'200	1'337'100	
HTM-5 1/4"-4UN/BH	5 1/4"-4UN	7,87	4,88	18	20	7,76	0,39	6,73	0,57	424	1'089'900	1'458'400	
HTM-5 1/2"-4UN/BH	5 1/2"-4UN	8,07	4,88	19	20	8,03	0,39	6,73	0,57	424	1'150'600	1'538'200	
HTM-5 3/4"-4UN/BH	5 3/4"-4UN	8,46	4,88	21	20	8,43	0,39	6,73	0,57	417	1'249'400	1'670'800	
HTM-6"-4UN/BH	6"-4UN	8,86	4,88	22	20	8,74	0,39	6,73	0,57	424	1'331'500	1'782'000	

\* Tightening torque per pressure bolt  
 \*\* approx. 75% of the max. preload  
 \*\*\* approx. 70 to 75ksi preload in the thread

For sizes under 4 3/4", please use the CH or DH series.



Scan to download the 3D-Data

### GRADE CH

Type	Nut body			Pressure bolts		Washer		Tension nut		Torque	Preload				
	Thread Ø [in]	TPI P <sub>1</sub>	Outer-Ø D <sub>o</sub> [in]	Height h [in]	Quantity n	Width across flats SW [mm]	Outer-Ø D <sub>w</sub> [in]	Thickness w [in]	Total height H [in]		Tensioning stroke a [in]	Nominal* M <sub>A</sub> [lbf]	Nominal** F <sub>Vnom</sub> [lbs]	Maximum*** F <sub>Vmax</sub> [lbs]	
HTM-D-TPI/CH															
HTM-1"-.../CH	1"	14UN	12UN	8UN	1,97	0,94	8	7	1,93	0,16	1,65	0,20	13	46'100	59'600
HTM-1 1/8"-.../CH	1 1/8"	12UN	8UN	7UN	2,20	1,10	9	8	2,17	0,16	1,91	0,22	18	56'200	75'300
HTM-1 1/4"-.../CH	1 1/4"	12UN	8UN	7UN	2,32	1,10	10	8	2,28	0,16	1,91	0,22	20	70'800	95'500
HTM-1 3/8"-.../CH	1 3/8"	12UN	8UN	6UN	2,72	1,38	7	10	2,68	0,20	2,36	0,30	44	85'400	114'600
HTM-1 1/2"-.../CH	1 1/2"	12UN	8UN	6UN	2,83	1,38	8	10	2,76	0,20	2,36	0,30	47	103'400	139'300
HTM-1 5/8"-.../CH	1 5/8"	12UN	8UN	6UN	2,95	1,38	9	10	2,91	0,20	2,36	0,30	50	123'600	164'000
HTM-1 3/4"-.../CH	1 3/4"	12UN	8UN	5UN	3,31	1,65	8	12	3,27	0,24	2,85	0,37	74	138'200	187'600
HTM-1 7/8"-.../CH	1 7/8"	12UN	8UN	6UN	3,46	1,65	9	12	3,39	0,24	2,85	0,37	77	162'900	219'100
HTM-2"-.../CH	2"	12UN	8UN	4,5UN	3,58	1,65	10	12	3,50	0,24	2,85	0,37	77	182'000	247'200
HTM-2 1/4"-.../CH	2 1/4"	12UN	8UN	4,5UN	4,17	2,05	9	14	4,13	0,31	3,43	0,41	133	242'700	321'300
HTM-2 1/2"-.../CH	2 1/2"	12UN	8UN	4UN	4,33	2,05	10	14	4,29	0,31	3,43	0,41	136	277'500	373'000
HTM-2 3/4"-.../CH	2 3/4"	8UN	6UN	4UN	4,88	2,52	10	16	4,84	0,31	4,09	0,49	188	332'600	442'700
HTM-3"-.../CH	3"	8UN	6UN	4UN	5,04	2,52	12	16	5,00	0,31	4,09	0,49	188	398'900	534'800
HTM-3 1/4"-.../CH	3 1/4"	8UN	6UN	4UN	5,39	2,99	15	16	5,35	0,31	4,57	0,49	181	479'800	636'000
HTM-3 1/2"-.../CH	3 1/2"	8UN	6UN	4UN	5,87	3,46	13	18	5,83	0,39	5,14	0,53	273	561'800	746'100
HTM-3 3/4"-.../CH	3 3/4"	8UN	6UN	4UN	6,06	3,46	15	18	6,02	0,39	5,14	0,53	273	647'200	864'000
HTM-4"-.../CH	4"	8UN	6UN	4UN	6,69	3,94	14	20	6,65	0,39	5,79	0,57	372	744'900	991'000
HTM-4 1/4"-.../CH	4 1/4"	8UN	6UN	4UN	6,89	3,94	15	20	6,85	0,39	5,79	0,57	395	844'900	1'128'100
HTM-4 1/2"-.../CH	4 1/2"	8UN	6UN	4UN	7,32	4,41	17	20	7,28	0,39	6,26	0,57	395	957'300	1'271'900
HTM-4 3/4"-.../CH	4 3/4"	8UN	6UN	4UN	7,83	4,41	13	24	7,80	0,47	6,71	0,73	690	1'070'800	1'425'800
HTM-5"-.../CH	5"	8UN	6UN	4UN	8,07	4,41	15	24	8,19	0,47	6,71	0,73	664	1'189'900	1'587'600

\* Tightening torque per pressure bolt  
 \*\* Approx. 75% of the max. preload  
 \*\*\* Approx. 90% of the elastic limit of a bolt according to ASTM A354 grade BC

For sizes over 5" please use the BH series.

## PRODUCT OVERVIEW

### GRADE DH

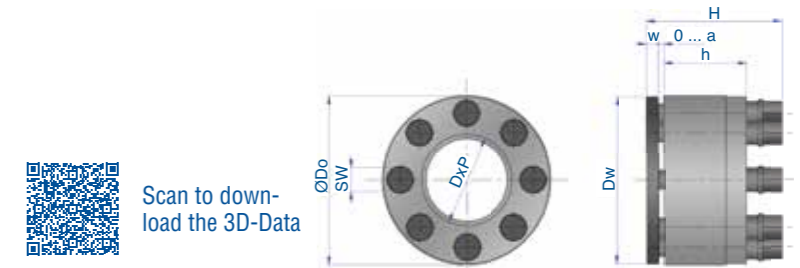

Scan to download the 3D-Data

Type	Nut body			Pressure bolts		Washer		Tension nut		Torque	Preload				
	Thread Ø [in]	TPI P <sub>1</sub>	Outer-Ø D <sub>o</sub> [in]	Height h [in]	Quantity n	Width across flats SW [mm]	Outer-Ø D <sub>w</sub> [in]	Thickness w [in]	Total height H [in]		Tensioning stroke a [in]	Nominal* M <sub>A</sub> [lbf]	Nominal** F <sub>Vnom</sub> [lbs]	Maximum*** F <sub>Vmax</sub> [lbs]	
HTM-D-TPI/DH															
HTM-1"-.../DH	1"	14UN	12UN	8UN	1,97	0,94	12	7	1,93	0,16	1,65	0,20	13	60'700	79'800
HTM-1 1/8"-.../DH	1 1/8"	12UN	8UN	7UN	2,20	1,10	12	8	2,17	0,16	1,91	0,22	18	74'200	100'000
HTM-1 1/4"-.../DH	1 1/4"	12UN	8UN	7UN	2,60	1,30	8	10	2,56	0,20	2,20	0,30	43	96'600	127'000
HTM-1 3/8"-.../DH	1 3/8"	12UN	8UN	6UN	2,72	1,38	10	10	2,68	0,20	2,36	0,30	41	113'500	151'700
HTM-1 1/2"-.../DH	1 1/2"	12UN	8UN	6UN	2,83	1,38	12	10	2,80	0,20	2,36	0,30	41	139'300	184'300
HTM-1 5/8"-.../DH	1 5/8"	12UN	8UN	6UN	3,19	1,57	10	12	3,15	0,24	2,70	0,37	70	164'000	220'200
HTM-1 3/4"-.../DH	1 3/4"	12UN	8UN	5UN	3,31	1,65	11	12	3,27	0,24	2,85	0,37	72	186'500	249'400
HTM-1 7/8"-.../DH	1 7/8"	12UN	8UN	6UN	3,46	1,65	12	12	3,39	0,24	2,85	0,37	77	218'000	291'000
HTM-2"-.../DH	2"	12UN	8UN	4,5UN	3,86	1,97	11	14	3,82	0,31	3,31	0,37	111	247'200	328'100
HTM-2 1/4"-.../DH	2 1/4"	12UN	8UN	4,5UN	4,17	2,05	13	14	4,13	0,31	3,43	0,41	122	321'300	425'800
HTM-2 1/2"-.../DH	2 1/2"	12UN	8UN	4UN	4,57	2,36	12	16	4,57	0,31	3,94	0,49	184	391'000	523'600
HTM-2 3/4"-.../DH	2 3/4"	8UN	6UN	4UN	5,16	2,52	12	18	5,12	0,39	4,15	0,53	225	427'000	570'800
HTM-3"-.../DH	3"	8UN	6UN	4UN	5,43	2,83	13	18	5,28	0,39	4,51	0,53	251	515'700	689'900
HTM-3 1/4"-.../DH	3 1/4"	8UN	6UN	4UN	5,91	3,31	13	20	5,91	0,39	5,14	0,55	332	615'700	821'300
HTM-3 1/2"-.../DH	3 1/2"	8UN	6UN	4UN	6,30	3,31	14	20	6,18	0,39	5,14	0,55	361	722'500	962'900
HTM-3 3/4"-.../DH	3 3/4"	8UN	6UN	4UN	6,81	3,70	11	24	6,77	0,47	6,00	0,73	638	838'200	1'115'700
HTM-4"-.../DH	4"	8UN	6UN	4UN	7,09	3,94	12	24	7,05	0,47	6,24	0,73	671	961'800	1'279'800

\* Tightening torque per pressure bolt  
 \*\* Approx. 75% of the max. preload  
 \*\*\* Approx. 90% of the elastic limit of a bolt according to ASTM A354 grade BD

For sizes over 4" please use the CH or BH series.

All HEICO TEC® Tension Nuts can optionally be ordered with a zinc flake coating for better protection against corrosion. Other coatings or stainless steel materials are available upon request.

More information about the HEICO-TEC® Tension Nuts can be found at [www.heico-tec.com](http://www.heico-tec.com)



## HEICO-TEC® COMPACT SERIES

### SAFE AND COMPACT

The HEICO-TEC® Compact Series was specially developed for applications where limited space is available in both axial and in radial directions or, in relation to the classic, high-strength tension nut series (strength class 8 or 10), a more moderate preload level must be generated.

The target is to generate the optimum out of the available installation space and the maximum preload force that can be generated.

- The standard dimension range is M20 - M160
- Available in blank (uncoated) and zinc flake coated versions
- Other dimensions, coating systems or materials are available upon request

Basically, the HEICO-TEC® Compact Series consists of two standard series:

#### HTM/FL

#### FLAT VERSION; LIGHT SERIES

Compactness is the focus of the FL series. The FL series is suitable for the tightest applications with the most difficult accessibility. The preload force capacity is lower compared to the FS series.

#### HTM/FS

#### FLAT VERSION; HEAVY SERIES

The FS series offers a significantly higher preload capacity with a very compact design. As a result, relatively high preload forces can be generated even in the tightest spaces.



### DESIGN AND FUNCTION

- In contrast to the HEICO-TEC® Tension Nuts of strength class 8 and 10 the HEICO-TEC® Compact Series uses high-strength set screws with internal drive.
- Inserting the set screws into the nut body allows a significantly more compact design concept, since the overall height of the tension nut is the total height of nut body and washer (set screws do not protrude from nut body).
- For the assembly of the set screws, conventional hex socket bits are used.
- The thread stripping strength of the Compact Series is dramatically improved by the special nut body / washer geometry.

## HEICO-TEC® COMPACT SERIES

### APPLICATION

#### Rotating or dynamically loaded components:

The HEICO-TEC® FL and FS series are tailored to the needs of rotating machine assemblies and can optionally be equipped with captive set screws. Due to the centering of the washer on the collar tension nuts of class FL and FS are much easier to balance than, for example tension nuts of series 8/10. Therefore they contribute positively to the overall balancing process at large distances from the axis of rotation.

Further advantages can be seen in the fact that the set screws do not protrude out of the nut body and are not standing in the flow of the surrounding media. With this property, the set screws are also largely protected against the influence of abrasive media. The tension nuts can therefore be equipped with the maximum thread engagement for the available overall heights.

The collar shifts the introduction of the force into the main thread (down) and reduces in combination with the selected pitch circle the local loads on the main thread. Altogether, these properties achieve an improved life time for example with dynamic operating forces and ensure a more homogeneous load distribution in the tension nut. As the nut body dips into the washer the result is the largest possible thread stripping strength of its class.



#### Installation spaces:

HEICO-TEC® Compact Series Tension Nuts can be used in almost any space designed for flat hexagon nuts.

Since there are no key faces, there is no need for tools on the outside diameter. The countersink design of the set screws further guarantees improved accessibility in confined spaces during the assembly.

In contrast to our standard profile tension nuts of series 8 and 10, the Compact Series can also be used on threaded rods, continuous shafts or on hydraulic cylinders (torque wrench fits next to the thread or the piston rod) due to the offset pitch circle diameter.





# HEICO-TEC® COMPACT SERIES (METRIC)

# HEICO-TEC® COMPACT SERIES (METRIC)

## PRODUCT OVERVIEW

### STRENGTH CLASS FL

Flat version, light series



Scan to download the 3D-Data

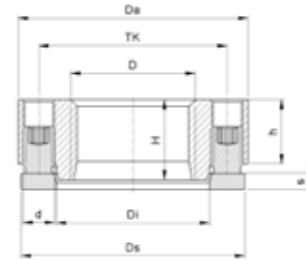

Type	Nut body			Pressure bolts		Washer		Tension nut		Torque Nominal* M <sub>nom</sub> [Nm]	Preload	
	Thread D	Outer-Ø Da [mm]	Thread height H [mm]	Quantity n	Width across flats	Ø D <sub>w</sub> [mm]	Thickness s [mm]	Total height H [mm]	Tensioning stroke a [mm]		Nominal** F <sub>vinom</sub> [kN]	Maximum*** F <sub>vmax</sub> [kN]
HTM-20x2,5/FL	M20	41	12	7	1/8"	41	3	12	3	5,5	70	95
HTM-22x2,5/FL	M22	43	13	8	1/8"	43	3	13	3	5,5	80	110
HTM-24x3/FL	M24	46	14	10	1/8"	46	3	14	3	5,5	105	140
HTM-27x3/FL	M27	54	16	7	3/16"	54	4	16	4	14	135	185
HTM-30x3,5/FL	M30	58	17	8	3/16"	58	4	17	4	15	170	225
HTM-33x3,5/FL	M33	61	18	10	3/16"	61	4	18	4	15	205	275
HTM-36x4/FL	M36	70	20	7	7/32"	70	5	20	5	28	225	305
HTM-39x4/FL	M39	73	21	8	7/32"	73	5	21	5	29	270	360
HTM-42x4,5/FL	M42	77	22	9	7/32"	77	5	22	5	30	315	420
HTM-45x4,5/FL	M45	80	23	10	7/32"	80	5	23	5	30	350	465
HTM-48x5/FL	M48	89	25	8	9/32"	89	6	25	6	52	400	535
HTM-52x5/FL	M52	94	27	9	9/32"	94	6	27	6	52	450	600
HTM-56x5,5/FL	M56	98	29	10	9/32"	98	6	29	6	54	520	695
HTM-60x5,5/FL	M60	103	31	11	9/32"	103	6	31	6	54	575	765
HTM-64x6/FL	M64	113	33	9	5/16"	113	8	33	7	86	650	865
HTM-68x6/FL	M68	117	35	10	5/16"	117	8	35	7	85	715	950
HTM-72x6/FL	M72	123	37	11	5/16"	123	8	37	7	85	785	1045
HTM-76x6/FL	M76	127	39	12	5/16"	127	8	39	7	83	835	1115
HTM-80x6/FL	M80	136	40	9	3/8"	136	8	40	8	135	890	1185
HTM-85x6/FL	M85	143	41	10	3/8"	143	8	41	8	130	950	1270
HTM-90x6/FL	M90	148	42	11	3/8"	148	8	42	8	130	1045	1395
HTM-95x6/FL	M95	153	43	12	3/8"	153	8	43	8	125	1100	1465
HTM-100x6/FL	M100	161	45	13	3/8"	161	8	45	8	125	1190	1585
HTM-105x6/FL	M105	166	46	14	3/8"	166	8	46	8	120	1230	1640
HTM-110x6/FL	M110	183	47	8	12mm	183	10	47	10	275	1310	1750
HTM-115x6/FL	M115	188	48	8	12mm	188	10	48	10	290	1385	1845
HTM-120x6/FL	M120	193	49	8	12mm	193	10	49	10	300	1430	1910
HTM-125x6/FL	M125	198	49	8	12mm	198	10	49	10	310	1480	1975
HTM-130x6/FL	M130	203	50	9	12mm	203	10	50	10	285	1530	2040
HTM-140x6/FL	M140	214	50	9	12mm	214	10	50	10	290	1555	2075
HTM-150x6/FL	M150	224	50	10	12mm	224	10	50	10	265	1580	2110
HTM-160x6/FL	M160	234	50	10	12mm	234	10	50	10	265	1580	2110

\* Tightening torque per pressure bolt. Tightening torque and pretensioning force are proportional, i.e. half the tightening torque results in half the pretensioning force.  
 \*\* Tension nut can be preloaded to nom. preload force.  
 \*\*\* Tension nut can be reactively loaded up to max. preload force.

## PRODUCT OVERVIEW

### STRENGTH CLASS FS

Flat version, heavy series



Scan to download the 3D-Data

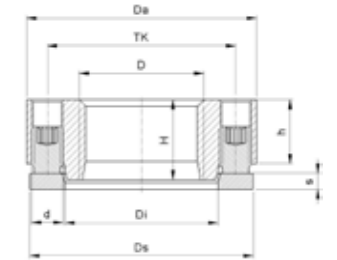

Type	Nut body			Pressure bolts		Washer		Tension nut		Torque Nominal* M <sub>nom</sub> [Nm]	Preload	
	Thread D	Outer-Ø Da [mm]	Thread height H [mm]	Quantity n	Width across flats	Ø D <sub>w</sub> [mm]	Thickness s [mm]	Total height H [mm]	Tensioning stroke a [mm]		Nominal** F <sub>vinom</sub> [kN]	Maximum*** F <sub>vmax</sub> [kN]
HTM-20x2,5/FS	M20	46	16	5	3/16"	46	4	16	4	13	90	120
HTM-22x2,5/FS	M22	48	18	5	3/16"	48	4	18	4	15	105	140
HTM-24x3/FS	M24	51	20	7	3/16"	51	4	20	4	14	135	185
HTM-27x3/FS	M27	59	22	5	7/32"	59	5	22	5	29	165	225
HTM-30x3,5/FS	M30	63	24	7	7/32"	63	5	24	5	27	220	290
HTM-33x3,5/FS	M33	66	26	8	7/32"	66	5	26	5	29	270	360
HTM-36x4/FS	M36	75	28	6	9/32"	75	6	28	6	58	335	445
HTM-39x4/FS	M39	78	30	8	9/32"	78	6	30	6	52	400	535
HTM-42x4,5/FS	M42	82	32	9	9/32"	82	6	32	6	56	485	650
HTM-45x4,5/FS	M45	90	34	8	5/16"	90	8	34	7	86	575	770
HTM-48x5/FS	M48	94	36	9	5/16"	94	8	36	7	89	670	895
HTM-52x5/FS	M52	99	38	11	5/16"	99	8	38	7	85	785	1045
HTM-56x5,5/FS	M56	108	41	9	3/8"	108	8	41	8	140	920	1230
HTM-60x5,5/FS	M60	113	44	11	3/8"	113	8	44	8	135	1085	1450
HTM-64x6/FS	M64	118	47	12	3/8"	118	8	47	8	140	1230	1640
HTM-68x6/FS	M68	132	50	8	12mm	132	10	50	10	300	1430	1910
HTM-72x6/FS	M72	138	54	9	12mm	138	10	54	10	295	1585	2110
HTM-76x6/FS	M76	142	58	10	12mm	142	10	58	10	295	1760	2345
HTM-80x6/FS	M80	156	62	8	14mm	156	12	62	12	490	1930	2575
HTM-85x6/FS	M85	163	65	9	14mm	163	12	65	12	480	2125	2835
HTM-90x6/FS	M90	168	68	10	14mm	168	12	68	12	475	2340	3120
HTM-95x6/FS	M95	173	71	11	14mm	173	12	71	12	475	2575	3430
HTM-100x6/FS	M100	181	74	12	14mm	181	12	74	12	470	2780	3705
HTM-105x6/FS	M105	186	76	12	14mm	186	12	76	12	500	2955	3940
HTM-110x6/FS	M110	193	78	13	14mm	193	12	78	12	490	3140	4185
HTM-115x6/FS	M115	198	79	14	14mm	198	12	79	12	480	3310	4415
HTM-120x6/FS	M120	203	81	14	14mm	203	12	81	12	505	3485	4645
HTM-125x6/FS	M125	208	83	16	14mm	208	12	83	12	460	3625	4835
HTM-130x6/FS	M130	213	85	16	14mm	213	12	85	12	475	3745	4995
HTM-140x6/FS	M140	224	86	18	14mm	224	12	86	12	445	3945	5260
HTM-150x6/FS	M150	234	87	18	14mm	234	12	87	12	460	4080	5440
HTM-160x6/FS	M160	244	88	20	14mm	244	12	88	12	415	4090	5455

\* Tightening torque per pressure bolt. Tightening torque and pretensioning force are proportional, i.e. half the tightening torque results in half the pretensioning force.  
 \*\* Tension nut can be preloaded to nom. preload force.  
 \*\*\* Tension nut can be reactively loaded up to max. preload force.



## SECURING OF HEICO-TEC® TENSION NUTS

HEICO-TEC® Tension Nuts are used in a wide variety of industrial sectors and offer the possibility to generate very high preload forces with the highest tightening accuracy, thereby reducing the risk of self-loosening. For bolted connections that are exposed to strong vibrations or dynamic loads an integration of additional backup methods listed below is recommended:

### 1. Anti-rotation device

This security system guarantees effective and reliable security of the tension nut. This is a patented and tested anti-rotation system, which allows quick and easy assembly as well as disassembly. It's inexpensive, can be used for both new and old existing systems and can also be reused.

- The main bolt (1) is inserted through the common hole into the parts that need to be connected.
- A HEICO-LOCK® Wedge Lock Washer (2) under the head of the bolt prevents it from loosening.
- The bolt (1) is preloaded with a tension nut.
- A HEICO-TEC® anti-rotation disc (4) is placed on the pressure bolts of the HEICO-TEC® Tension Nut (3). The anti-rotation disc is secured with the bolt (5) onto the main bolt (1), which is equipped with a centrally threaded hole.
- The bolt (5) is secured with another HEICO-LOCK® Wedge Lock Washer (6).

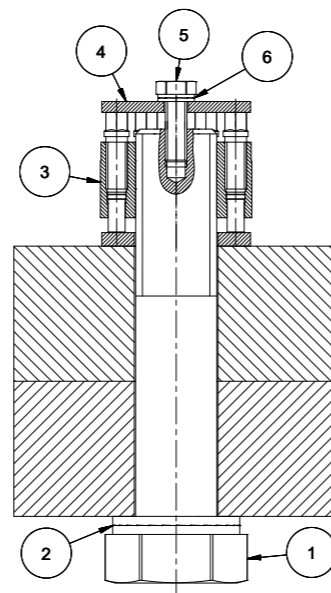

### 2. Securing by wire

HEICO-TEC® Tension Nuts can be designed in such a way that the pressure bolts have a cross hole in the pressure bolt head. This allows the adjacent pressure bolts to be safety wired to one another after assembly.

### 3. Loss prevention with set screws

HEICO-TEC® Tension Nuts that are equipped with set screws can be designed in such a way that unscrewing of the set screws cannot be done. This is guaranteed by appropriate design measures and is only available upon request.

### 4. Radial pin integration

HEICO-TEC® Tension Nuts can be provided with an additional, radial threaded hole. After initial positioning of the Tension Nut body with a ¼ counterclockwise turn, the position is set so that a threaded pin can be inserted through the radial bore through the nut body and into the main thread. This creates an interlocking loss prevention element for the nut body. Normally this backup method is only used for customer-specific tension nuts.

## PREPARATION

The bolt thread and the contact surface have to be clean and free from burrs. Place the washer on the mating surface and center it. Now hand-tighten the tension nut. Then turn the tension nut back approx. ¼ turn so that there is a small gap between the tension nut and the washer.



The QR code will take you to the assembly video of the HT Tension Nut.

## ASSEMBLY

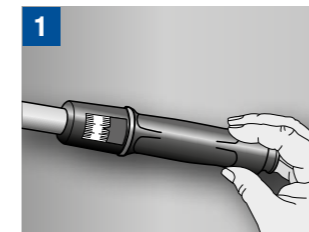

Set torque wrench to recommended tightening torque.

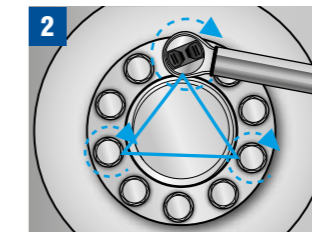

Hand-tighten any three pressure bolts, approx. equally spaced from each other, in sequence so that the pressure bolts touch the thrust washer.

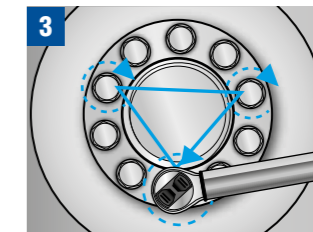

Tighten three other pressure bolts that are approx. equally spaced from each other with the recommended tightening torque.

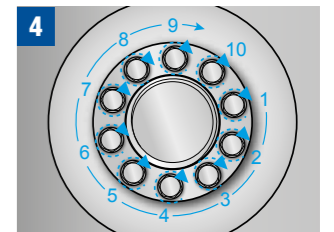

In a circular pattern tighten all pressure bolts with the recommended tightening torque. Repeat this step until all pressure bolts are tightened equally.

Then, under load, tighten the three pressure bolts alternately by max. ½ turn each until the recommended torque is reached.

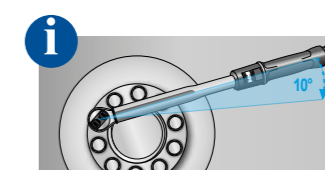

It is sufficient if the torque wrench moves less than 10° before it clicks.

## DISASSEMBLY

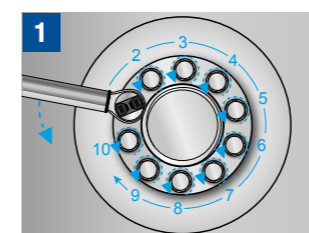

In a circular pattern starting with any pressure bolt break each pressure bolt loose so that it turns slightly.

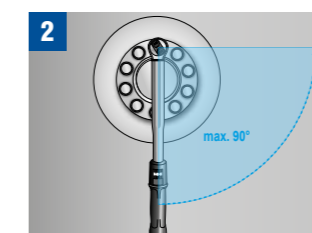

In a circular pattern loosen each pressure bolt max. ¼ turn. Repeat this step twice.

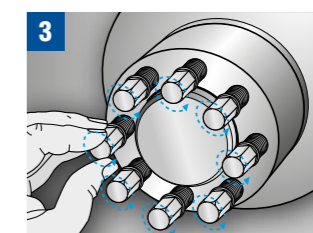

After three unloading rounds the pressure bolts should be unloaded sufficiently so they may be loosened completely one after another. Otherwise repeat step 2 as often as required.

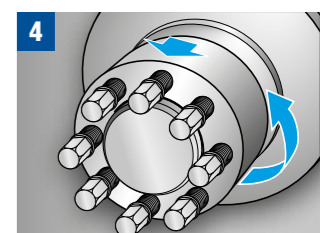

Screw off tension nut and remove washer.

## HEICO-TEC® REACTION NUT

## ADVANTAGES OF HEICO-TEC® REACTION NUT

### ELASTIC · DURABLE · SECURE

HEICO-TEC® Reaction Nuts are the ideal complement to the HEICO-TEC® Tension Nut for use with through-bolted connections. If you already enjoy the advantages of HEICO-TEC® Tension Nuts for active pre-tensioning, you need an equivalent reactive nut on the opposite end. Due to their special shape, HEICO-TEC® Reaction Nuts can flex elastically. And the more elastic a bolted joint is, the more durable and secure it is against untightening and loosening.

### COMPATIBLE WITH ISO 898-2

HEICO-TEC® Reaction Nuts meet all requirements of ISO 898-2. They therefore have the same strength as conventional hex nuts and can replace them 1:1. However, they must not be used for active pre-tensioning, rather only on the opposite reactive end.

### CONSTRUCTION AND FUNCTION

1. The nut body ① is screwed onto the bolt like a conventional nut with the main thread, but is not tightened. Tensioning is performed from the opposite end, e.g. with a HEICO-TEC® Tension Nut.

2. Since the nut body only rests on the outer diameter, a hardened washer ② protects the clamped parts from the contact pressure.

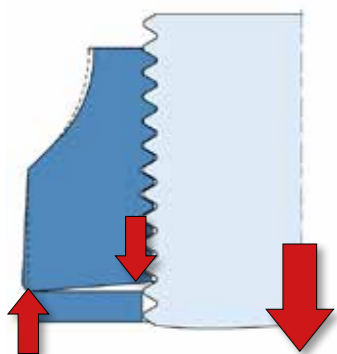

The contact surface of the HEICO-TEC® Reaction Nut is concave and can therefore flex elastically in the direction of the bolt axis. This increases the elasticity of the bolted joint. A short bolted joint is susceptible to fatigue failure and self-loosening. With the HEICO-TEC® Reaction Nut the joint performs like a bolted joint which is 2-3 thread diameters longer and thus more durable and safer. This is accomplished solely by replacing the hex nut with a HEICO-TEC® Reaction Nut!

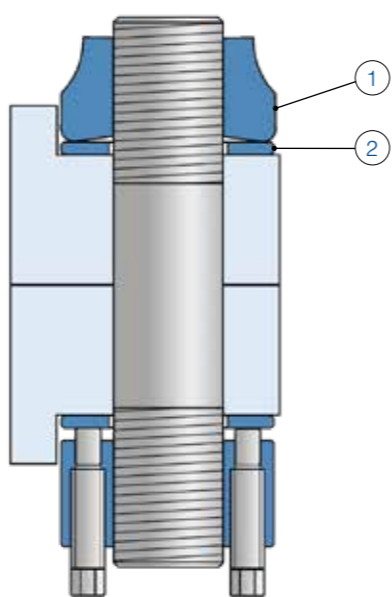

#### SPACE SAVING

In contrast to similar products, HEICO-TEC® Reaction Nuts have the same dimensions as the active HEICO-TEC® Tension Nut for the nut body and the washer. This means they do not require any additional space.



#### REUSABLE

HEICO-TEC® Reaction Nuts are entirely reusable. The bolted joint will not be damaged during tightening and loosening.



#### COMPATIBLE

HEICO-TEC® Reaction Nuts meet all requirements of ISO 898-2. They can replace any conventional nut with the same strength class as long as they are only reactively loaded and are not used for active tensioning.



#### ELASTIC

In contrast to other spring based fasteners such as disc springs or spring washers, which are simply flattened and then ineffective, HEICO-TEC® Reaction Nuts remain elastic up to the maximum bolt force according to ISO 898-1.



#### DURABLE

The more elastic a bolt is in relation to the clamped parts, the less stress it will be subjected to. Due to their flexing, HEICO-TEC® Reaction Nuts reduce the load on the bolt and thus increase the durability of the bolted joint.



#### SECURE

Also the more elastic a bolted joint is, the less susceptible it is to untightening and self-loosening. The additional elasticity stored in the HEICO-TEC® Reaction Nuts counteracts preload losses due to settling or creeping. This ensures that the bolted joint remains securely tightened.



# HEICO-TEC® REACTION NUT

# HEICO-TEC® REACTION NUT

The HEICO-TEC® Reaction Nut offers decisive advantages compared to other products:

## HEX NUTS

Conventional hex nuts are very rigid and have little elasticity.

**Problem:**

In the thread the preload acts in tension, while an equally high compressive force is generated on the contact surface of the hex nut. As a result, the preload force is very strongly deflected in the first load-bearing threads and leads to an uneven load distribution. This is why bolts often break here.

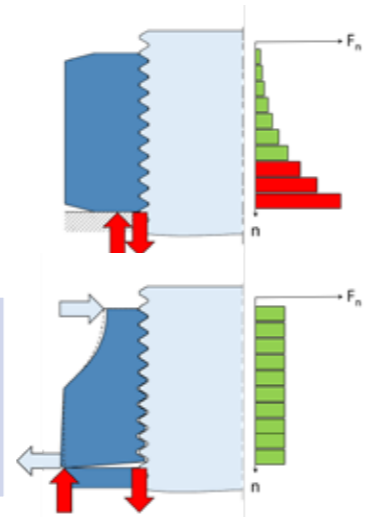

### ADVANTAGE OF THE HEICO-TEC® REACTION NUT

The concave contact surface of the HEICO-TEC® Reaction Nut creates an almost even load distribution in the thread. **The service life of the bolts is significantly increased!**

## SPRING WASHERS

Each bolted joint (blue) loses preload force  $\Delta F$  by settling or creeping  $\Delta f$ . Often an attempt is made to increase the elasticity of the bolted joint with a conventional spring washer in order to extend the service life on one hand and to counteract loosening and self-loosening on the other.

**Problem:**

Spring washers are already flattened under 50% of the preload force (orange). This renders them ineffective.

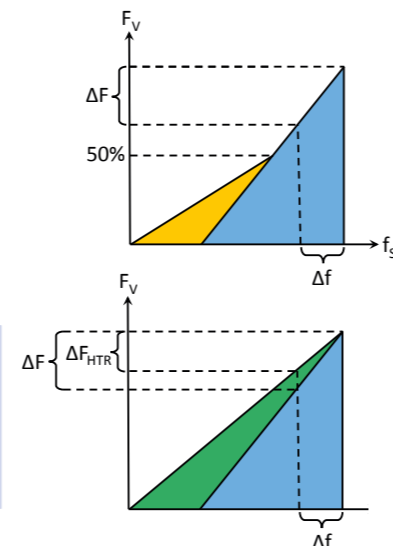

### ADVANTAGE OF THE HEICO-TEC® REACTION NUT

The HEICO-TEC® Reaction Nut (green) remains elastic up to the full preload. **Preload losses  $\Delta F_{HTR}$  are effectively reduced!**

## REACTION NUTS OF OTHER MANUFACTURERS

Other manufacturers also offer reaction nuts.

**Problem:**

They usually have a larger outside diameter and a larger washer than the active tension nut on the opposite side. Therefore they need more space.

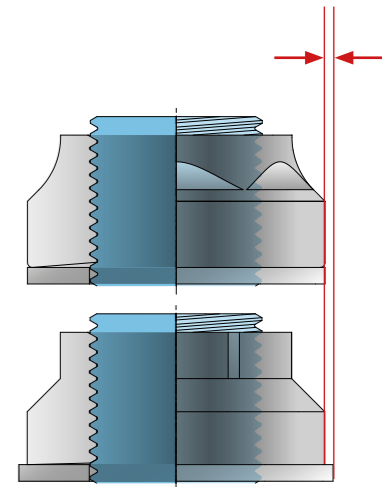

### ADVANTAGE OF THE HEICO-TEC® REACTION NUT

The HEICO-TEC® Tension Nut and Reaction Nut have the same dimensions. Thus, their position is interchangeable. **No additional space is required!**

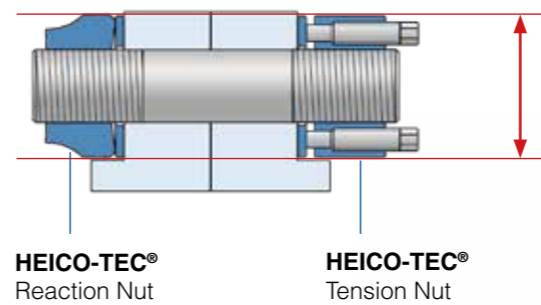

Tension nuts and reaction nuts have the same dimensions



# HEICO-TEC® REACTION NUT (METRIC)

## PRODUCT OVERVIEW

### STRENGTH CLASS 8



Scan to download the 3D-Data

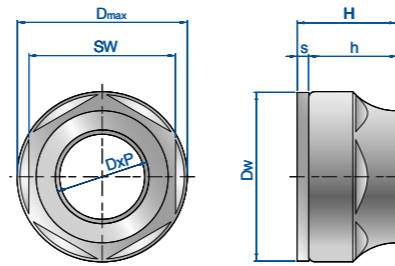

Type	Nut body			Washer		Reaction nut		Preload	
	Thread D <sub>xP</sub>	Outer-Ø D <sub>max</sub> [mm]	Height h [mm]	Outer-Ø D <sub>w</sub> [mm]	Thickness s [mm]	Total height H [mm]	Width across flats [mm]	Nominal* F <sub>Vnom</sub> [kN]	Maximum** F <sub>Vmax</sub> [kN]
HTR-M24x3/8	M24x3	44	20	43	4	24	36	195	225
HTR-M27x3/8	M27x3	50	24	49	4	28	41	245	285
HTR-M30x3,5/8	M30x3,5	56	28	55	5	33	46	300	360
HTR-M33x3,5/8	M33x3,5	59	28	58	5	33	50	365	445
HTR-M36x4/8	M36x4	69	35	68	5	40	55	440	525
HTR-M39x4/8	M39x4	72	35	71	5	40	60	525	625
HTR-M42x4,5/8	M42x4,5	75	35	74	5	40	60	600	720
HTR-M45x4,5/8	M45x4,5	84	42	83	6	48	65	685	840
HTR-M48x5/8	M48x5	87	42	86	6	48	70	805	945
HTR-M52x5/8	M52x5	91	42	90	6	48	75	930	1125
HTR-M56x5,5/8	M56x5,5	102	52	101	8	60	85	1095	1300
HTR-M60x5,5/8	M60x5,5	106	52	105	8	60	90	1260	1500
HTR-M64x6/8	M64x6	110	52	109	8	60	95	1435	1665
HTR-M68x6/8	M68x6	120	64	119	8	72	100	1645	1930
HTR-M72x6/8	M72x6	124	64	123	8	72	105	1855	2145
HTR-M76x6/8	M76x6	128	64	127	8	72	110	2090	2490
HTR-M80x6/8	M80x6	132	76	131	8	84	110	2340	2780
HTR-M85x6/8	M85x6	137	76	136	8	84	115	2655	3170
HTR-M90x6/8	M90x6	149	88	148	10	98	125	3005	3580
HTR-M95x6/8	M95x6	154	88	153	10	98	130	3350	4020
HTR-M100x6/8	M100x6	159	88	158	10	98	135	3740	4480
HTR-M105x6/8	M105x6	170	100	169	10	110	145	4165	4965
HTR-M110x6/8	M110x6	175	100	174	10	110	150	4570	5400
HTR-M115x6/8	M115x6	186	112	185	10	122	165	5020	6015
HTR-M120x6/8	M120x6	195	112	194	10	122	170	5525	6490

\* Approx. 2/3 of the breaking load of a screw of strength class 8.8  
 \*\* Approx. elasticity limit of a screw of strength class 8.8

All series of the HEICO-TEC® Reaction Nuts are marked with the strength class according to ISO 898-2. Other strength classes, sizes, pitches or thread forms are available on request.

# HEICO-TEC® REACTION NUT (METRIC)

## PRODUCT OVERVIEW

### STRENGTH CLASS 10



Scan to download the 3D-Data

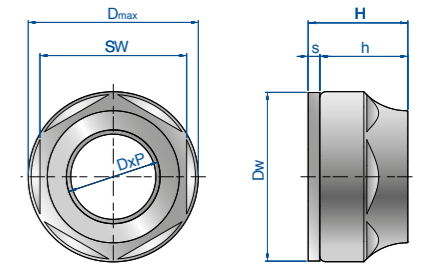

Type	Nut body				Washer		Reaction nut		Preload	
	Thread D	Pitch P	Outer-Ø D <sub>max</sub> [mm]	Height h [mm]	Outer-Ø D <sub>w</sub> [mm]	Thickness s [mm]	Total height H [mm]	Width across flats [mm]	Nominal* F <sub>Vnom</sub> [kN]	Maximum** F <sub>Vmax</sub> [kN]
HTR-M20x.../10	M20	2,5 2 1,5	40	20	39	4	24	32	180	220
HTR-M22x.../10	M22	2,5 2 1,5	42	20	41	4	24	34	235	265
HTR-M24x.../10	M24	3 2 1,5	46	24	45	4	28	36	260	320
HTR-M27x.../10	M27	3 2 1,5	50	24	49	4	28	41	350	410
HTR-M30x.../10	M30	3,5 2 1,5	56	28	55	5	33	46	425	505
HTR-M33x.../10	M33	3,5 2 1,5	66	33	65	5	38	50	515	625
HTR-M36x.../10	M36	4 3 1,5	69	35	68	5	40	55	620	740
HTR-M39x.../10	M39	4 3 1,5	72	35	71	5	40	60	725	880
HTR-M42x.../10	M42	4,5 3 1,5	81	40	80	6	46	65	845	1010
HTR-M45x.../10	M45	4,5 3 1,5	84	42	83	6	48	70	975	1180
HTR-M48x.../10	M48	5 3 1,5	88	42	87	6	48	75	1110	1330
HTR-M52x.../10	M52	5 3 2	98	50	97	8	58	80	1320	1585
HTR-M56x.../10	M56	5,5 4 2	102	52	101	8	60	85	1520	1830
HTR-M60x.../10	M60	5,5 4 2	110	52	109	8	60	90	1780	2130
HTR-M64x.../10	M64	6 4 2	116	60	115	8	68	95	2020	2420
HTR-M68x.../10	M68	6 4 2	120	64	119	8	72	100	2300	2750
HTR-M72x.../10	M72	6 4 2	134	64	133	10	74	110	2585	3120
HTR-M76x.../10	M76	6 4 2	138	72	137	10	82	115	2935	3510
HTR-M80x.../10	M80	6 4 2	147	72	146	10	82	120	3270	3910
HTR-M85x.../10	M85	6 4 2	150	84	149	10	94	125	3715	4460
HTR-M90x.../10	M90	6 4 2	160	84	159	10	94	130	4200	5040
HTR-M95x.../10	M95	6 4 2	173	94	172	12	106	145	4700	5560
HTR-M100x.../10	M100	6 4 2	182	94	181	12	106	150	5245	6110

The exact article designation is generated by replacing the „...“ with the desired gradient.

\* Approx. 2/3 of the breaking load of a screw of strength class 10.9  
 \*\* Approx. elasticity limit of a screw of strength class 10.9

All series of the HEICO-TEC® Reaction Nuts are marked with the strength class according to ISO 898-2. Other strength classes, sizes, pitches or thread forms are available on request.



# HEICO-TEC® REACTION NUT (INCH)

# HEICO-TEC® REACTION NUT (INCH)

## PRODUCT OVERVIEW

### GRADE CH



Scan to download the 3D-Data

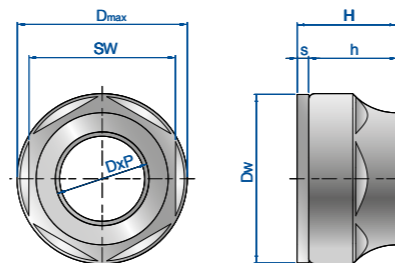

Type	Nut body			Washer		Reaction nut		Preload	
	Thread DxP	Outer-Ø D <sub>max</sub> [mm]	Height h [mm]	Outer-Ø D <sub>w</sub> [mm]	Thickness s [mm]	Total height H [mm]	Width across flats [mm]	Nominal* F <sub>Vnom</sub> [kN]	Maximum** F <sub>Vmax</sub> [kN]
HTR-1"-8UN/CH	1"-8UN	1,97	0,94	1,93	0,16	1,10	41	46'100	59'600
HTR-1 1/8"-7UN/CH	1 1/8"-7UN	2,20	1,10	2,17	0,16	1,26	46	56'200	75'300
HTR-1 1/4"-7UN/CH	1 1/4"-7UN	2,32	1,10	2,28	0,16	1,26	50	70'800	95'500
HTR-1 3/8"-6UN/CH	1 3/8"-6UN	2,72	1,38	2,68	0,20	1,58	50	85'400	114'600
HTR-1 1/2"-6UN/CH	1 1/2"-6UN	2,83	1,38	2,76	0,20	1,58	55	103'400	139'300
HTR-1 5/8"-6UN/CH	1 5/8"-6UN	2,95	1,38	2,91	0,20	1,58	60	123'600	164'000
HTR-1 3/4"-5UN/CH	1 3/4"-5UN	3,31	1,65	3,27	0,24	1,89	65	138'200	187'600
HTR-1 7/8"-5UN/CH	1 7/8"-5UN	3,46	1,65	3,39	0,24	1,89	70	162'900	219'100
HTR-2"-4,5UN/CH	2"-4,5UN	3,58	1,65	3,50	0,24	1,89	75	182'000	247'200
HTR-2 1/4"-4,5UN/CH	2 1/4"-4,5UN	4,17	2,05	4,13	0,31	2,36	90	242'700	321'300
HTR-2 1/2"-4UN/CH	2 1/2"-4UN	4,33	2,05	4,29	0,31	2,36	95	277'500	373'000
HTR-2 3/4"-4UN/CH	2 3/4"-4UN	4,88	2,52	4,84	0,31	2,83	105	332'600	442'700
HTR-3"-4UN/CH	3"-4UN	5,04	2,52	5,00	0,31	2,83	110	398'900	534'800
HTR-3 1/4"-4UN/CH	3 1/4"-4UN	5,39	2,99	5,35	0,31	3,30	115	479'800	636'000
HTR-3 1/2"-4UN/CH	3 1/2"-4UN	5,87	3,46	5,83	0,39	3,85	125	561'800	746'100
HTR-3 3/4"-4UN/CH	3 3/4"-4UN	6,06	3,46	6,02	0,39	3,85	130	647'200	864'000
HTR-4"-4UN/CH	4"-4UN	6,69	3,94	6,65	0,39	4,33	135	744'900	991'000
HTR-4 1/4"-4UN/CH	4 1/4"-4UN	6,89	3,94	6,85	0,39	4,33	150	844'900	1'128'100
HTR-4 1/2"-4UN/CH	4 1/2"-4UN	7,32	4,41	7,28	0,39	4,80	165	957'300	1'271'900
HTR-4 3/4"-4UN/CH	4 3/4"-4UN	7,83	4,41	7,80	0,47	4,88	170	1'070'800	1'425'800
HTR-5"-4UN/CH	5"-4UN	8,07	4,41	8,19	0,47	4,88	180	1'189'900	1'587'600

\* Approx. 75% of maximal preload

\*\* Approx. 90% of the elastic limit of a bolt according to ASTM A354 grade BC

## PRODUCT OVERVIEW

### GRADE DH



Scan to download the 3D-Data

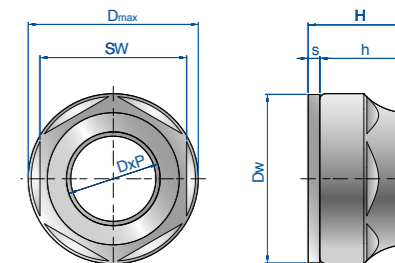

Type	Nut body			Washer		Reaction nut		Preload	
	Thread DxP	Outer-Ø D <sub>max</sub> [mm]	Height h [mm]	Outer-Ø D <sub>w</sub> [mm]	Thickness s [mm]	Total height H [mm]	Width across flats [mm]	Nominal* F <sub>Vnom</sub> [kN]	Maximum** F <sub>Vmax</sub> [kN]
HTR-1"-8UN/DH	1"-8UN	1,97	0,94	1,93	0,16	1,10	41	60'700	79'800
HTR-1 1/8"-7UN/DH	1 1/8"-7UN	2,20	1,10	2,17	0,16	1,26	46	74'200	100'000
HTR-1 1/4"-7UN/DH	1 1/4"-7UN	2,60	1,30	2,56	0,20	1,50	50	96'600	127'000
HTR-1 3/8"-6UN/DH	1 3/8"-6UN	2,72	1,38	2,68	0,20	1,58	55	113'500	151'700
HTR-1 1/2"-6UN/DH	1 1/2"-6UN	2,83	1,38	2,80	0,20	1,58	60	139'300	184'300
HTR-1 5/8"-6UN/DH	1 5/8"-6UN	3,19	1,57	3,15	0,24	1,81	65	164'000	220'200
HTR-1 3/4"-5UN/DH	1 3/4"-5UN	3,31	1,65	3,27	0,24	1,89	70	186'500	249'400
HTR-1 7/8"-5UN/DH	1 7/8"-5UN	3,46	1,65	3,39	0,24	1,89	70	218'000	291'000
HTR-2"-4,5UN/DH	2"-4,5UN	3,86	1,97	3,82	0,31	2,28	80	247'200	328'100
HTR-2 1/4"-4,5UN/DH	2 1/4"-4,5UN	4,17	2,05	4,13	0,31	2,36	95	321'300	425'800
HTR-2 1/2"-4UN/DH	2 1/2"-4UN	4,57	2,36	4,57	0,31	2,67	100	391'000	523'600
HTR-2 3/4"-4UN/DH	2 3/4"-4UN	5,16	2,52	5,12	0,39	2,91	110	427'000	570'800
HTR-3"-4UN/DH	3"-4UN	5,43	2,83	5,28	0,39	3,22	115	515'700	689'900
HTR-3 1/4"-4UN/DH	3 1/4"-4UN	5,91	3,31	5,91	0,39	3,70	125	615'700	821'300
HTR-3 1/2"-4UN/DH	3 1/2"-4UN	6,30	3,31	6,18	0,39	3,70	130	722'500	962'900
HTR-3 3/4"-4UN/DH	3 3/4"-4UN	6,81	3,70	6,77	0,47	4,17	135	838'200	1'115'700
HTR-4"-4UN/DH	4"-4UN	7,09	3,94	7,05	0,47	4,41	140	961'800	1'279'800

\* Tightening torque per pressure bolt

\*\* Approx. 90% of the elastic limit of a screw according to ASTM A354 grade BD

For dimensions bigger than 4 inches, use the CH series.

All series of the HEICO-TEC® Reaction Nuts are marked with the strength class according to ISO 898-2. Other strength classes, sizes, pitches or thread forms are available on request.





## HEICO-TEC® TENSION BOLT AND MULTI-TOOL

## HEICO-TEC® PROTECTION CAPS

### HEICO-TEC® TENSION BOLT

For applications where the use of a tension nut and shaft is not possible due to lack of available space, we also offer our HEICO-TEC® Tension Bolt. This product is designed with a head diameter that is no larger than that of a standard hex nut ensuring its suitability for tight installation spaces.



### HEICO-TEC® MULTI-TOOL

HEICO-TEC® Tension Nuts can be tightened and untightened by hand due to manageable torque values of the many small pressure bolts. That's what makes the application easy, reliable and safe. Especially for the installation of HEICO-TEC® Tension Nuts in serial production environments, HEICO developed the HEICO-TEC® Multi-Tool. Using the HEICO-TEC® Multi-Tool the pressure bolts of the HEICO-TEC® Tension Nut can be tightened with little manual effort of the worker – easy as simply pushing a button.

#### Advantages:

- Pressure bolts are tightened with the same torque, so there is no manual control with a torque wrench required.
- Effortless attachment thanks to spring-loaded sockets.
- Existing hydraulic units can easily be used without problems.
- For optimizing factory series production.



Scan the QR code for more information on the functional principle of the HEICO-TEC® Multi-Tool.



The HEICO-TEC® Multi-Tool is offered on a project basis. Each tool is designed and constructed for the customer's application. We would be happy to advise you and give you detailed information on the ordering process.

HEICO offers protection caps for all standard series HEICO-TEC® Tension Nuts.

### HEICO-TEC® PROTECTION CAPS

HEICO offers suitable protection caps for the standard HEICO-TEC® Tension Nuts program.

The HEICO-TEC® Protection Caps made of a durable elastomer protect the entire tension nut from external, aggressive environmental influences in operation. In combination with coated HEICO-TEC® Tension Nuts, they are especially recommended for use in highly corrosive environments, e.g. in offshore areas. The HEICO-TEC® Protection Caps are greased before assembly and can easily be fitted on the tension nut.



#### Protection caps according to your individual requirements

In addition to the standard HEICO-TEC® Protection Caps customized solutions are also available, e.g. protection caps made of metal (e.g. stainless steel) or with integrated sealing function for high-pressure applications (e.g. in the offshore or hydropower sector).

Talk to us, we have the right solution for your requirement.



PRODUCT OVERVIEW

FOR TENSION NUTS CLASS 8

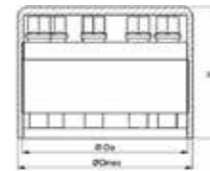

Product description Protection Cap	Outer Diameter Protection Cap [Do]	Nut body + Protection Cap (assembled)			Protection Cap (disassembled)	
		Nut body DxP	Outer-Ø D <sub>max</sub> [mm]	Height H [mm]	Outer-Ø [mm]	Total height H [mm]
Protection Cap M20/8	Protection Cap for Ø40	M20x2,5/8	45	42	44	42
Protection Cap M22/8	Protection Cap for Ø42	M22x2,5/8	47	42	46	42
Protection Cap M24/8	Protection Cap for Ø44	M24x3/8	49	42	48	42
Protection Cap M27/8	Protection Cap for Ø50	M27x3/8	55	47	54	47
Protection Cap M30/8	Protection Cap for Ø56	M30x3,5/8	61	55	60	55
Protection Cap M33/8	Protection Cap for Ø59	M33x3,5/8	64	55	63	55
Protection Cap M36/8	Protection Cap for Ø69	M36x4/8	74	65	73	65
Protection Cap M39/8	Protection Cap for Ø72	M39x4/8	77	65	76	65
Protection Cap M42/8	Protection Cap for Ø75	M42x4,5/8	80	65	79	65
Protection Cap M45/8	Protection Cap for Ø84	M45x4,5/8	89	78	88	78
Protection Cap M48/8	Protection Cap for Ø87	M48x5/8	92	78	91	78
Protection Cap M52/8	Protection Cap for Ø91	M52x5/8	96	78	95	78
Protection Cap M56/8	Protection Cap for Ø102	M56x5,5/8	107	92	106	92
Protection Cap M60/8	Protection Cap for Ø106	M60x5,5/8	111	92	110	92
Protection Cap M64/8	Protection Cap for Ø110	M64x6/8	115	92	114	92
Protection Cap M68/8	Protection Cap for Ø120	M68x6/8	125	109	124	109
Protection Cap M72/8	Protection Cap for Ø124	M72x6/8	129	109	128	109
Protection Cap M76/8	Protection Cap for Ø128	M76x6/8	133	109	132	109
Protection Cap M80/8	Protection Cap for Ø132	M80x6/8	137	121	136	121
Protection Cap M85/8	Protection Cap for Ø137	M85x6/8	142	121	141	121
Protection Cap M90/8	Protection Cap for Ø149	M90x6/8	154	134	153	134
Protection Cap M95/8	Protection Cap for Ø154	M95x6/8	159	134	158	134
Protection Cap M100/8	Protection Cap for Ø159	M100x6/8	164	135	163	135
Protection Cap M105/8	Protection Cap for Ø170	M105x6/8	175	152	174	152
Protection Cap M110/8	Protection Cap for Ø175	M110x6/8	180	152	179	152
Protection Cap M115x6/8	Protection Cap for Ø186	M115x6/8	191	164	190	164
Protection Cap M120x6/8	Protection Cap for Ø195	M120x6/8	200	164	199	164
Protection Cap M125x6/8	Protection Cap for Ø203	M125x6/8	208	181	207	181
Protection Cap M130x6/8	Protection Cap for Ø208	M130x6/8	215	183	213	183
Protection cap M140x6/8	Protection Cap for Ø215	M140x6/8	222	183	220	183
Protection Cap M150x6/8	Protection Cap for Ø236	M150x6/8	243	198	241	198
Protection Cap M160x6/8	Protection Cap for Ø272	M160x6/8	279	198	277	198

Other sizes are available on request.

PRODUCT OVERVIEW

FOR TENSION NUTS CLASS 10

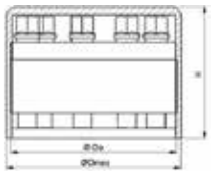

Product description Protection Cap	Outer diameter Tension Nut [Do]	Nut body + Protection Cap (assembled)			Protection Cap (disassembled)	
		Nut body DxP	Outer-Ø D <sub>max</sub> [mm]	Height H [mm]	Outer-Ø [mm]	Total height H [mm]
Protection Cap M20/10	Protection Cap for Ø40	M20x2,5/10	45	42	44	42
Protection Cap M22/10	Protection Cap for Ø42	M22x2,5/10	47	42	46	42
Protection Cap M24/10	Protection Cap for Ø46	M24x3/10	51	47	50	47
Protection Cap M27/10	Protection Cap for Ø50	M27x3/10	55	47	54	47
Protection Cap M30/10	Protection Cap for Ø56	M30x3,5/10	61	55	60	55
Protection Cap M33/10	Protection Cap for Ø66	M33x3,5/10	71	61	70	61
Protection Cap M36/10	Protection Cap for Ø69	M36x4/10	74	65	73	65
Protection Cap M39/10	Protection Cap for Ø72	M39x4/10	77	65	76	65
Protection Cap M42/10	Protection Cap for Ø81	M42x4,5/10	86	74	85	74
Protection Cap M45/10	Protection Cap for Ø84	M45x4,5/10	89	78	88	78
Protection Cap M48/10	Protection Cap for Ø88	M48x5/10	93	78	92	78
Protection Cap M52/10	Protection Cap for Ø98	M52x5/10	103	89	102	89
Protection Cap M56/10	Protection Cap for Ø102	M56x5,5/10	107	92	106	92
Protection Cap M60/10	Protection Cap for Ø110	M60x5,5/10	115	92	114	82
Protection Cap M64/10	Protection Cap for Ø116	M64x6/10	121	115	120	115
Protection Cap M68/10	Protection Cap for Ø120	M68x6/10	125	109	124	109
Protection Cap M72/10	Protection Cap for Ø134	M72x6/10	139	111	138	111
Protection Cap M76/10	Protection Cap for Ø138	M76x6/10	143	120	142	120
Protection Cap M80/10	Protection Cap for Ø147	M80x6/10	152	120	151	120
Protection Cap M85/10	Protection Cap for Ø150	M85x6/10	155	135	154	135
Protection Cap M90/10	Protection Cap for Ø160	M90x6/10	165	136	164	136
Protection Cap M95/10	Protection Cap for Ø173	M95x6/10	178	158	177	158
Protection Cap M100/10	Protection Cap for Ø182	M100x6/10	187	158	186	158

Other sizes are available on request.



# HEICO-TEC® PROTECTION CAPS (INCH)

## PRODUCT OVERVIEW

### FOR TENSION NUTS GRADE CH



Product description Protection Cap	Outer Diameter Protection Cap [Do]	Nut body + Protection Cap (assembled)			Protection Cap (disassembled)	
		Nut body DxP	Outer-Ø D <sub>max</sub> [mm]	Height H [mm]	Outer-Ø [mm]	Total height H [mm]
<b>Protection Cap 3/4"/CH</b>	Protection Cap for Ø40	3/4"-10UN	45	42	44	42
<b>Protection Cap 7/8"/CH</b>	Protection Cap for Ø42	7/8"-9UN	47	42	46	42
<b>Protection Cap 1"/CH</b>	Protection Cap for Ø50	1"-8UN	55	47	54	47
<b>Protection Cap 1 1/8"/CH</b>	Protection Cap for Ø56	1 1/8"-7UN	61	55	60	55
<b>Protection Cap 1 1/4"/CH</b>	Protection Cap for Ø59	1 1/4"-7UN	64	55	63	55
<b>Protection Cap 1 3/8"/CH</b>	Protection Cap for Ø69	1 3/8"-6UN	74	65	73	65
<b>Protection Cap 1 1/2"/CH</b>	Protection Cap for Ø72	1 1/2"-6UN	77	65	76	65
<b>Protection Cap 1 5/8"/CH</b>	Protection Cap for Ø75	1 5/8"-6UN	80	65	79	65
<b>Protection Cap 1 3/4"/CH</b>	Protection Cap for Ø84	1 3/4"-5UN	89	78	88	78
<b>Protection Cap 1 7/8"/CH</b>	Protection Cap for Ø87	1 7/8"-5UN	92	78	91	78
<b>Protection Cap 2"/CH</b>	Protection Cap for Ø91	2"-8UN	96	78	95	78
<b>Protection Cap 2 1/4"/CH</b>	Protection Cap for Ø106	2 1/4"-4,5UN	111	92	110	92
<b>Protection Cap 2 1/2"/CH</b>	Protection Cap for Ø110	2 1/2"-4UN	115	92	114	92
<b>Protection Cap 2 3/4"/CH</b>	Protection Cap for Ø124	2 3/4"-4UN	129	109	128	109
<b>Protection Cap 3"/CH</b>	Protection Cap for Ø128	3"-4UN	133	109	132	109
<b>Protection Cap 3 1/4"/CH</b>	Protection Cap for Ø137	3 1/4"-4UN	142	121	141	121
<b>Protection Cap 3 1/2"/CH</b>	Protection Cap for Ø149	3 1/2"-4UN	154	134	153	134
<b>Protection Cap 3 3/4"/CH</b>	Protection Cap for Ø154	3 3/4"-4UN	159	136	158	136
<b>Protection Cap 4"/CH</b>	Protection Cap for Ø170	4"-4UN	175	152	174	152
<b>Protection Cap 4 1/4"/CH</b>	Protection Cap for Ø175	4 1/4"-4UN	180	152	179	152
<b>Protection Cap 4 1/2"/CH</b>	Protection Cap for Ø186	4 1/2"-4UN	191	164	190	164
<b>Protection Cap 4 3/4"/CH</b>	Protection Cap for Ø199	4 3/4"-4UN	205	176*	204	176
<b>Protection Cap 5"/CH</b>	Protection Cap for Ø205	5"-4UN	210	176*	209	176

\* Sizes may vary slightly.

Other sizes are available on request.

# HEICO-TEC® PROTECTION CAPS (INCH)

## PRODUCT OVERVIEW

### FOR TENSION NUTS GRADE DH

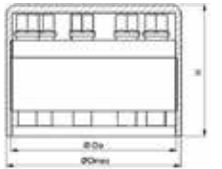

Product description Protection Cap	Outer Diameter Protection Cap [Do]	Nut body + Protection Cap (assembled)			Protection Cap (disassembled)	
		Nut body DxP	Outer-Ø D <sub>max</sub> [mm]	Height H [mm]	Outer-Ø [mm]	Total height H [mm]
<b>Protection Cap 3/4"/DH</b>	Protection Cap for Ø40	3/4"-10UN	45	42	44	42
<b>Protection Cap 7/8"/DH</b>	Protection Cap for Ø42	7/8"-9UN	47	42	46	42
<b>Protection Cap 1"/DH</b>	Protection Cap for Ø50	1"-8UN	55	47	54	47
<b>Protection Cap 1 1/8"/DH</b>	Protection Cap for Ø56	1 1/8"-7UN	61	55	60	55
<b>Protection Cap 1 1/4"/DH</b>	Protection Cap for Ø66	1 1/4"-7UN	72	61	71	61
<b>Protection Cap 1 3/8"/DH</b>	Protection Cap for Ø69	1 3/8"-6UN	74	65	73	65
<b>Protection Cap 1 1/2"/DH</b>	Protection Cap for Ø72	1 1/2"-6UN	77	65	76	65
<b>Protection Cap 1 5/8"/DH</b>	Protection Cap for Ø81	1 5/8"-6UN	86	74	85	74
<b>Protection Cap 1 3/4"/DH</b>	Protection Cap for Ø84	1 3/4"-5UN	89	78	88	78
<b>Protection Cap 1 7/8"/DH</b>	Protection Cap for Ø87	1 7/8"-5UN	92	78	91	78
<b>Protection Cap 2"/DH</b>	Protection Cap for Ø98	2"-4,5UN	103	89	102	89
<b>Protection Cap 2 1/4"/DH</b>	Protection Cap for Ø106	2 1/4"-4,5UN	111	92	110	92
<b>Protection Cap 2 1/2"/DH</b>	Protection Cap for Ø116	2 1/2"-4UN	121	105	120	105
<b>Protection Cap 2 3/4"/DH</b>	Protection Cap for Ø131	2 3/4"-4UN	136	111	135	111
<b>Protection Cap 3"/DH</b>	Protection Cap for Ø135	3"-4UN	140	120	139	120
<b>Protection Cap 3 1/4"/DH</b>	Protection Cap for Ø151	3 1/4"-4UN	156	136	155	136
<b>Protection Cap 3 1/2"/DH</b>	Protection Cap for Ø158	3 1/2"-4UN	162	136	162	136
<b>Protection Cap 3 3/4"/DH</b>	Protection Cap for Ø173	3 3/4"-4UN	178	158	177	158
<b>Protection Cap 4"/DH</b>	Protection Cap for Ø180	4"-4UN	185	164	184	164

Other sizes are available on request.

## SOCKETS

The HDS (Heavy-Duty Sockets) impact sockets are the ideal supplement for the professional assembly of HEICO-TEC® Tension Nuts.

The HDS impact sockets are designed for particularly strong stress cases and characterized by higher resiliency and a long lifetime of wear resistance compared to conventional sockets. In addition to the standard impact sockets, HEICO also offers a long version. This makes it easier to access hard-to-reach applications (e.g. those with strong protruding bolts).

HDS impact sockets conform to the international standards ISO 691, 1174-2, 1711-2, 2725-2 and 2725-3.

We would be happy to advise you which impact socket is suitable for your specific application.



**i** The product overview of impact sockets can be found on pages 36-37.

## ASSEMBLY KIT AND SPARE PARTS

Improper assembly and disassembly can damage the pressure bolts, pressure pins or thrust washer of the HEICO-TEC® Tension Nut or even cause them to be lost completely, e.g. during maintenance work. HEICO offers suitable assembly or spare part sets for such cases.

These are available to match every HEICO-TEC® Tension Nut of the standard series of strength classes 8 and 10. They consist of the respective number of pressure bolts and pressure pins as well as the corresponding thrust washer and are exclusively offered as a complete set.



## MOUNTING TEMPLATE

With the HEICO-TEC® Tension Nut, a fast and easy assembly is a certainty. In addition to the assembly guideline a mounting template for the tension nuts is available for the standard product range. It can aid the technician in tightening the pressure bolts correctly.

The template is placed on the tension nut. Following a color system, the pressure bolts are sequentially tightened: For example, first the orange ones, then the blue and finally the white markings. This cycle continues until the torque wrench shows the required tightening torques.

For easy documentation, the necessary tightening torque can be noted on the template and the filled-in template archived with the date as a receipt.



## LUBRICATION

To protect highly stressed parts of the HEICO-TEC® Tension Nut and to maintain constant coefficients of friction, HEICO recommends using the grease as protective, separating and lubricating medium.

The assembly paste contains an optimally matched and correct solids content along with selected additives and thus offers long-lasting protection against corrosion, galling and wear and tear.

Available in different quantities on request. We will gladly supply you with assembly pastes, which will be optimally suited to your specific application.



## PRODUCT OVERVIEW

### SOCKETS - STANDARD

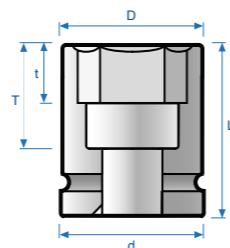

Product description	Item number	Drive	Socket size [mm]	Dimensions				
				Ø Wrench Side D [mm]	Ø Drive Side d [mm]	Total Length L [mm]	Socket Depth t [mm]	Total Depth T [mm]
HEICO-TEC HDS-1/4"-SW6	395300060000999	1/4"	6	10,1	13	25	4	15
HEICO-TEC HDS-3/8"-SW8	395300080000999	3/8"	8	13,5	19	33,5	6	21
HEICO-TEC HDS-1/2"-SW10	395300100000999	1/2"	10	17,0	25	38	7	22
HEICO-TEC HDS-1/2"-SW12	395300120000999	1/2"	12	19,7	25	38	8	22
HEICO-TEC HDS-1/2"-SW14	395300140000999	1/2"	14	22,5	25	38	10	22
HEICO-TEC HDS-1/2"-SW16	395300160000999	1/2"	16	24,5	30	38	10	20
HEICO-TEC HDS-3/4"-SW18	395300180000999	3/4"	18	31,0	44	50	11	24
HEICO-TEC HDS-3/4"-SW20	395300200000999	3/4"	20	33,0	44	50	12	24
HEICO-TEC HDS-3/4"-SW21	395300210000999	3/4"	21	35,0	44	50	12	24
HEICO-TEC HDS-3/4"-SW24	395300240000999	3/4"	24	38,5	44	50	14	24
HEICO-TEC HDS-1"-SW24	395301240000999	1"	24	38,0	54	59	14	27
HEICO-TEC HDS-1"-SW27	395300270000999	1"	27	44,0	54	59	16	27
HEICO-TEC HDS-1"-SW30	395300300000999	1"	30	50,0	54	61	17	29

Other sizes are available on request.



## PRODUCT OVERVIEW

### SOCKETS - LONG

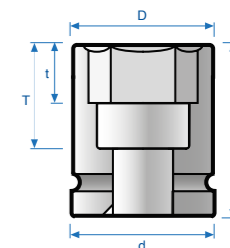

Product description	Item number	Drive	Socket size [mm]	Dimensions				
				Ø Wrench Side D [mm]	Ø Drive Side d [mm]	Total Length L [mm]	Socket Depth t [mm]	Total Depth T [mm]
HEICO-TEC HDS-3/8"-SW8-L	395300081000999	3/8"	8	13,5	19	57	5	45
HEICO-TEC HDS-1/2"-SW10-L	395300101000999	1/2"	10	17,0	25	82	7	64
HEICO-TEC HDS-1/2"-SW12-L	395300121000999	1/2"	12	19,7	25	82	8	64
HEICO-TEC HDS-1/2"-SW14-L	395300141000999	1/2"	14	22,5	25	82	10	64
HEICO-TEC HDS-1/2"-SW16-L	395300161000999	1/2"	16	24,5	30	82	10	64
HEICO-TEC HDS-3/4"-SW18-L	395300181000999	3/4"	18	32,0	44	100	11	74
HEICO-TEC HDS-3/4"-SW20-L	395300201000999	3/4"	20	34,0	44	100	12	74
HEICO-TEC HDS-3/4"-SW21-L	395300211000999	3/4"	21	36,0	44	100	12	74
HEICO-TEC HDS-3/4"-SW24-L	395300241000999	3/4"	24	39,5	44	100	14	74
HEICO-TEC HDS-1"-SW24-L	395301241000999	1"	24	39,0	54	100	14	68
HEICO-TEC HDS-1"-SW27-L	395300271000999	1"	27	45,0	54	100	16	68
HEICO-TEC HDS-1"-SW30-L	395300301000999	1"	30	51,0	54	100	17	68

Other sizes are available on request.



## HEICO SERVICE

### YOUR EXPERT FOR EFFICIENT AND DURABLE BOLT SECURING SOLUTIONS

Since 1900, the HEICO Group has been offering its customers the most reliable and high quality solutions in the field of fastening technology and can thus offer extensive know-how.

We do not only support you in choosing the right product, we also develop on your request tailor-made solutions for your requirements.

#### In addition, we offer you the following service:

- Training courses and seminars
- Support for assembly or installation problems
- Preparation of test reports in our in-house test laboratory
- 3D CAD data of our HEICO-TEC® products to download

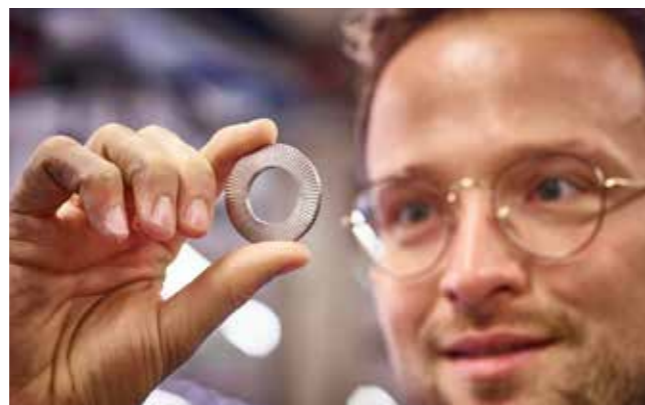

### YOUR CONCEPT QUICKLY IMPLEMENTED

If you work with HEICO, you get everything from a single source: From product development to testing in our in-house Laboratory, from toolmaking to mechanical engineering, from bolt know-how to certified production.

The versatility of the company ensures flexible processes and makes short reaction and delivery times possible. Together with the customer, the HEICO employees develop sophisticated solutions, no matter if standard projects or specific concepts.



#### HEICO 3D models in the CADENAS PARTcommunity

The 3D CAD data of the HEICO-TEC® products can be downloaded directly from the HEICO profile within the CADENAS PARTcommunity platform. After a free pre-registration at CADENAS all the product data is available at your disposal.



## OUTSTANDING HEICO QUALITY

### A HIGH ADDED VALUE FOR YOUR ADVANTAGE

HEICO customers benefit from an attractive service package, from which the company can pass the cost advantages to its customers thanks to the high level of added value.

Optimized processes create the economical conditions to be able to offer the standard products directly from stock. We produce the HEICO-TEC® Pressure Bolts and Pressure Pins on powerful multi-stage presses in either cold forming or warm processes.



### A STRONG GROUP BEHIND STRONG PRODUCTS

The HEICO Group from Ense in Westphalia is a family-owned business with a long tradition. Since the year 1900 the company has worked with passion in fastening technology. With its more than 430 employees and over a dozen company locations worldwide, the group offers the highest levels of technical advice, individual testing options and quality production.

For more information visit us at: [www.heico-group.com](http://www.heico-group.com)



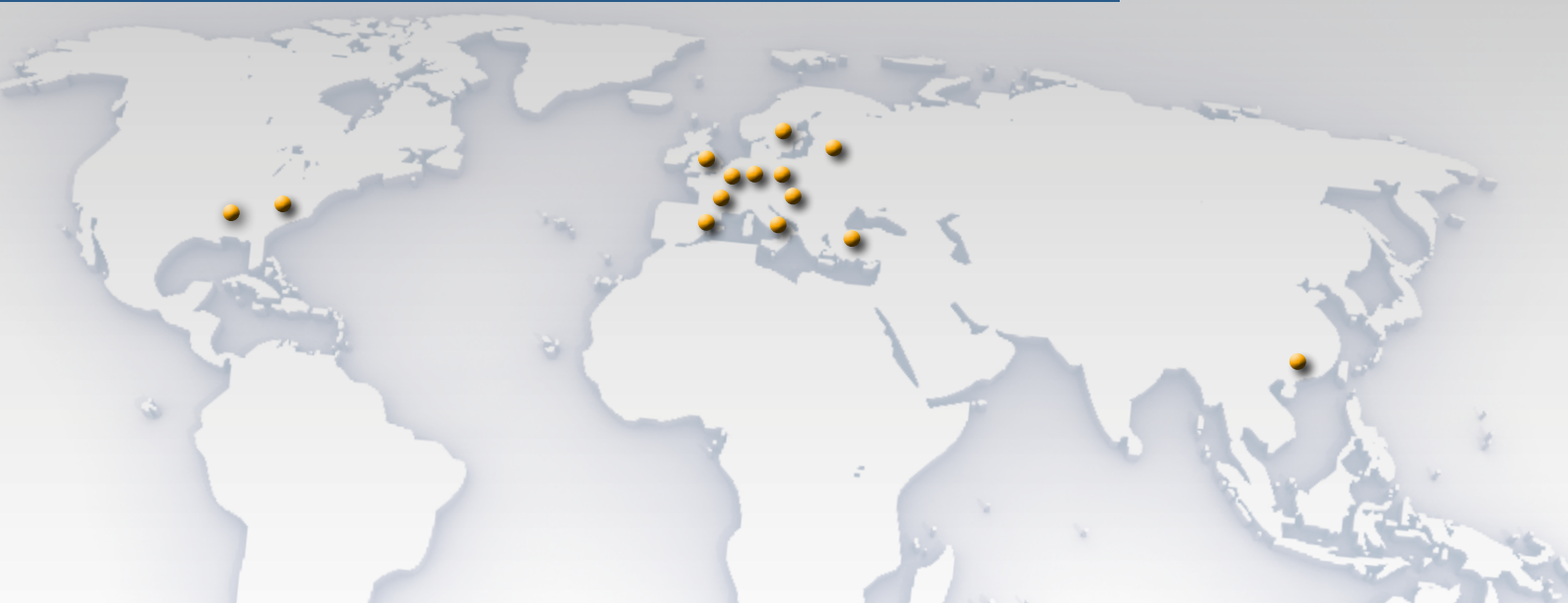

## The **HEICO-LOCK**<sup>®</sup> Wedge Locking Systems – high quality bolt security for demanding bolted connections!

In addition to the HEICO-TEC<sup>®</sup> Tensioning Systems the HEICO-LOCK<sup>®</sup> Wedge Locking Systems offer a reliable solution against self-loosening in demanding bolted connections – especially ones with dynamic loads!

Further information on the HEICO-LOCK<sup>®</sup> products can be found at [www.heico-lock.com](http://www.heico-lock.com)

